

CENTABUILD

BUILDING PRODUCTS

HEAD OFFICE: AUCKLAND (09) 579 0367
 WELLINGTON (04) 568 7086 • CHRISTCHURCH (03) 379 9364
www.centabuild.co.nz sales@centabuild.co.nz

CI/SfB

--	--	--	--

RH SEALS DATASHEET - AUG08

Product specifications can change. Contact us to ensure you have our latest datasheet

Rh SERIES AUTOMATIC DOOR BOTTOM SEAL

When door opens sealing gasket lifts clear of floor automatically. Used on single action doors. Fully rebated or surface mounted installation. Rh seals are normally installed by method 1.

- Suits NZ & Australian door sizes.
- Length easily cut to suit uncommon door sizes.
- Anodised Aluminium Housing.
- Left or right hand seals available.
- Allows for minor floor imperfections.
- Simple Reliable Mechanism.
- Tested to 1,000,000 opening and closing cycles.
- Under Door Gap 3mm to 12mm for RhP.
- Under Door Gap 6mm to 15mm for RhSi.
- PVC or Silicone Bulb Seal available.

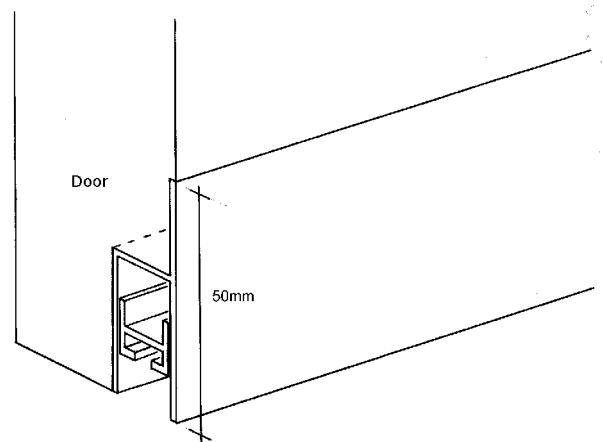
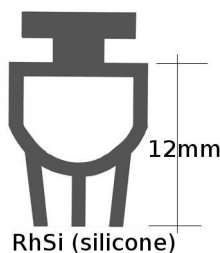
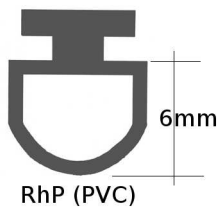

PVC and SILICONE seals both provide an effective barrier to weather, cold smoke, drafts, dust, and noise & smell. Due to its higher temperature melting point silicone is deemed to comply for use as a medium smoke seal for temperatures up to 200°C.

Product Codes

Rh Seal with PVC Bulb	Rh Seal with Silicone Bulb	For Door Widths up to
RhP-450	RhSi-450	450mm
RhP-610	RhSi-610	610mm
RhP-820	RhSi-820	820mm
RhP-950	RhSi-950	950mm
RhP-1220	RhSi-1220	1220mm

Special length seals can be manufactured from 380mm up to a maximum of 1335mm.

NOTE: Minimum order for specials, 20 lengths.

Installation

1. Select left or right activated seal. The designation left(L) or right(R) is assuming installation method 1 is used. If installation method 2 is used a (L) seal will be required if the activator is to be on the right. Most commonly this seal is installed by method 1.
2. Rebate the door to the required depth if Method 2 is selected.
3. If necessary cut seal to width required. Rh Seals in sizes 650mm to 970mm may be trimmed back to 650mm. Rh Seals in larger sizes may be trimmed back to 950mm. Do not trim back sizes under 650mm. If method 1 installation is used allow for thickness of door stops.
4. Glue or screw the seal to the door. Drill screw holes 10mm from each end and at no more than 200mm centres approximately 15mm from the top edge of the extrusion.
5. Insert end caps and glue in to place.
6. Attach closure plate to the door jamb.
7. Adjust Push-Rod/Activator with screwdriver for correct clearance.

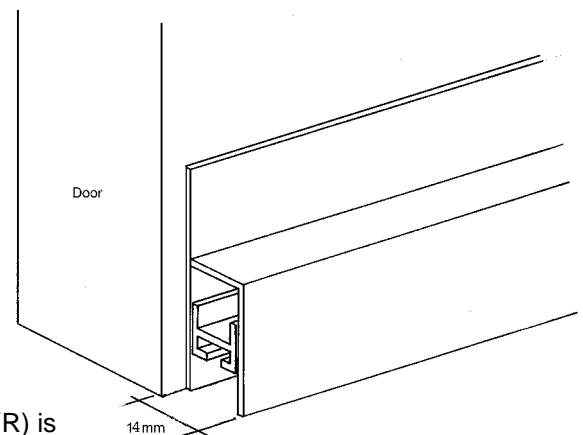

NOTE: The technical information and suggestions for use and application presented herein represent the best information available to us and are believed to be reliable. They should not however be construed as controlling suggestions and there is no warranty of performance of our materials either expressed or implied. We urge that users of our materials conduct confirmatory tests to determine final suitability for their specific end uses. All dimensions are nominal. **We reserve the right to make changes or to withdraw designs and products without notice.**